

AF 250 (Tier 3)

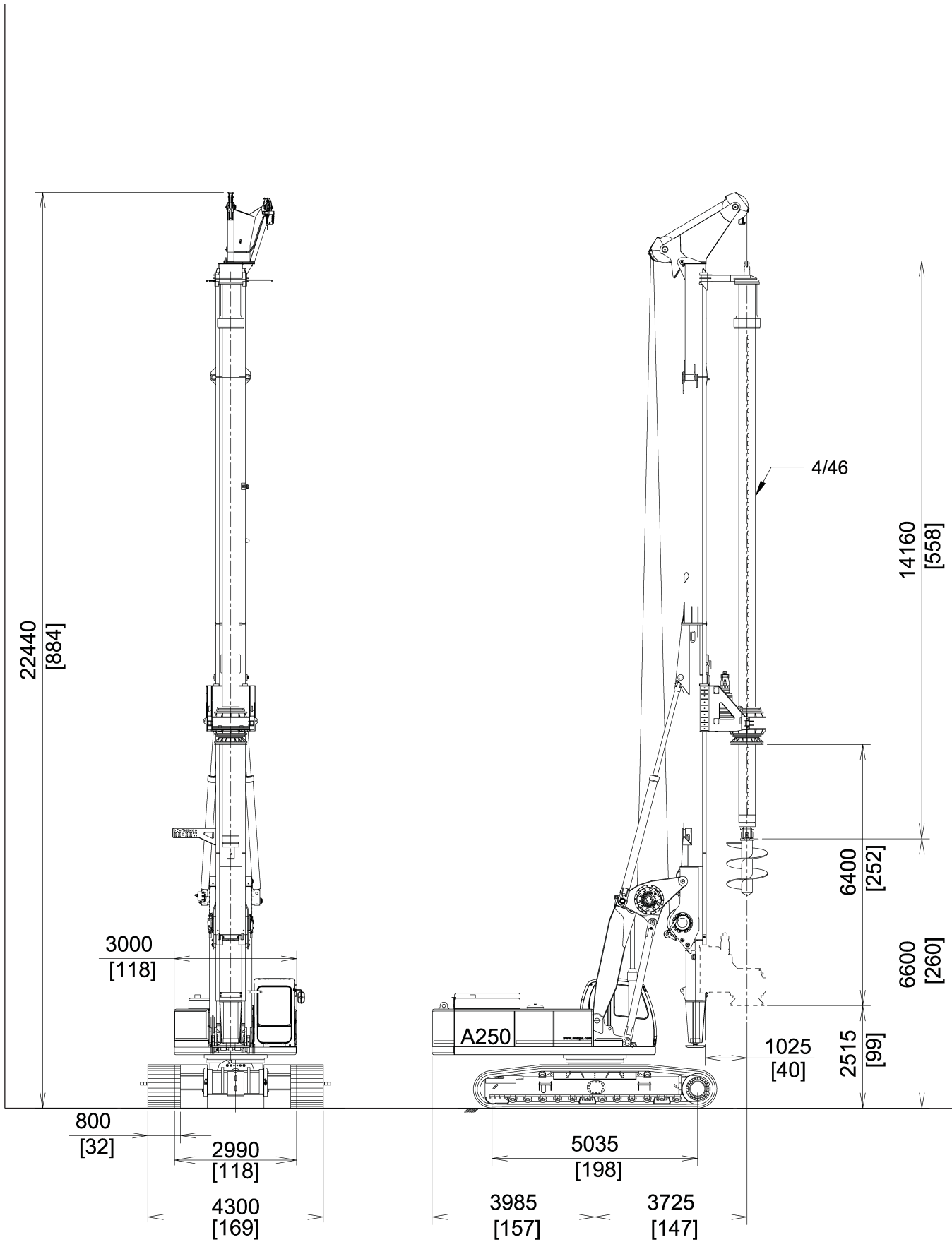

Base	Caterpillar 336D		Caterpillar 336D	
Undercarriage length / widening range / shoe	mm	CAT 5870/3000 - 4300/800	in	231/118 - 169/31,5
Engine type	CAT C9		CAT C9	
Power	261 KW (350 HP) @ 1800 rpm.		261 KW (350 HP) @1800 rpm.	
Rotary				
Installed torque	kNm	260	lbf ft	191770
Working speed	rpm	7 - 27	rpm	7 - 27
Discharge speed	rpm	45 - 110	rpm	45 - 110
Winches				
Main winch pull force	kN	240	lbf	53955
Main winch speed	m/min	73	ft/min	240
Main winch Cable diameter	mm	28	in	/
Auxiliary winch pull force	kN	120	lbf	26980
Auxiliary winch Speed	m/min	80	ft/min	262
Auxiliary winch Cable diameter	mm	22	in	/
Crowd system				
Kelly crowd push	kN	250	lbf	56205
Kelly crowd pull	kN	390	lbf	87680
Stroke	mm	6400	in	252
Mast				
Mast raking forward	5°		5°	
Mast side raking	±8°		±8°	
Mast raking backwards	15°		15°	
Pile max. diameter	mm	2000	in	79
Kelly bar				
Standard	4/46		4/46	
Options available	4/48 - 5/66		4/48 - 5/66	
Operating Weight w/standard kelly bar	t(metric)	69	lbs	152120

All technical data are indicatives and subject to change without notice.

